



Hoist / Motor Controller

Instruction Manual

Models:
MCP8-DV-CEE
MCP8-DV-8H6
MCP8-DV-2SX.4CEE
MCP8-DV-2H16.4CEE

Version 2.1 since 3 February 2020

ATTENTION!

This instruction manual contains important information about the installation and the use of the equipment. Please read and follow these instructions carefully.

Always ensure that the power to the equipment is disconnected before opening the equipment or commencing any maintenance work.

General information

IMPORTANT INSTRUCTIONS!

All safety and operating instructions should be read before the equipment is installed or operated.

IMPORTANT SAFETY INFORMATION

The following general safety precautions have to be observed during all phases of operation, service, and the repair of this equipment. Failure to comply with these precautions or with specific warnings in this manual violates safety standards of design, manufacture, and the intended use of this equipment.

Do not operate in an explosive atmosphere!

Do not operate this equipment in the presence of flammable gases or fumes. Operation of any electrical instrument in such an environment constitutes a definite safety hazard.

Water, moisture, heat and humidity

Do not operate this equipment near water, in areas with wet floors or in high humidity atmosphere where condensation forms on the equipment. It should never be placed near or over a heat register or other source of heated air and it should not be installed or operated without proper ventilation.

Functions and Control

Motor Controller is designed to control up to 8 electrically compatible direct voltage hoist/motors separately or simultaneously; controlled via cable remote controller with GO/STOP command.

Each device is equipped with MPA /Manual Phase Align/ module that allows changing the phases easily by rotating pins L2 and L3 on the main connector.

All electrical components carry their own individual CE and comply with European Directives. The components are housed in a robust steel 19" rack casing with powder coating. Unit complies with the CE according to the Certification of Conformity that is attached to this manual.

MCP8-DV-CEE

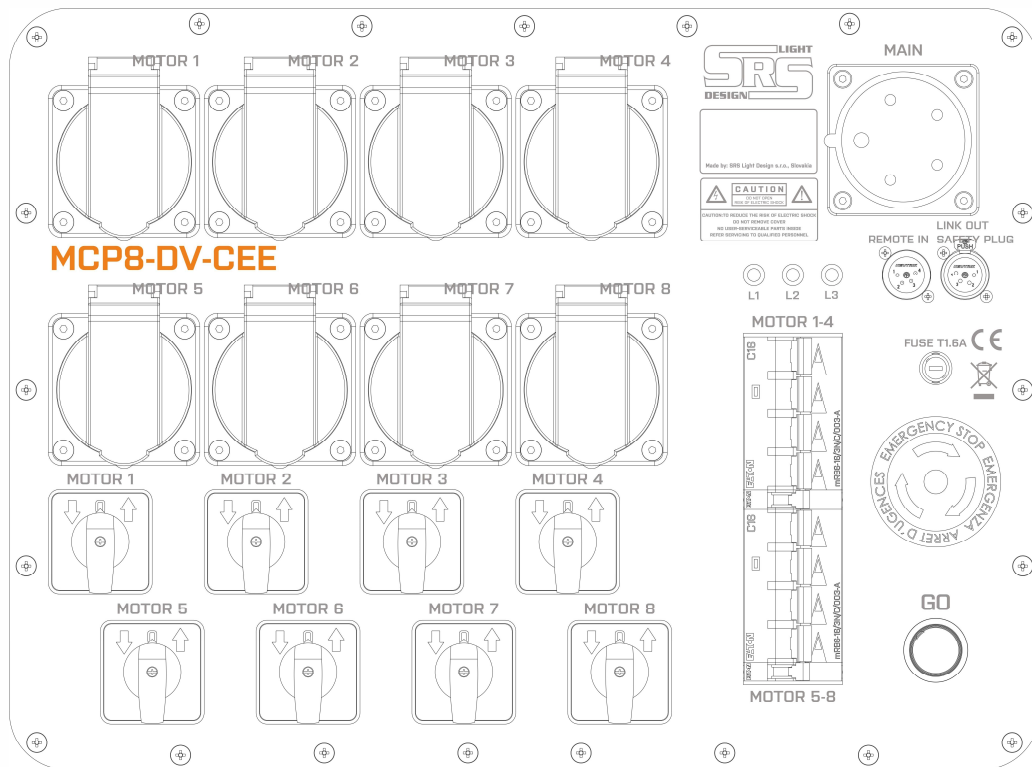

EMERGENCY STOP:

Emergency is a RED button located in the middle of yellow circle.

Emergency stop button turns the MCP8-DV-CEE controller to an inactive state and stays in it. To release it, rotate the emergency stop clockwise.

When several more controllers are linked together, the press of any E-STOP button will shut down all connected controllers.

GO:

When active, the green pushbutton turns the selected channels of Hoist Control system ON. Once the GO button is released, the energizing of the hoists is turned off.

LINK:

For link of several controllers use 4pin MC-x-LINK cable. Safety breach needs to be connected in last controller of chain. See schematics for more details.

MCP8-DV-2SX.4CEE

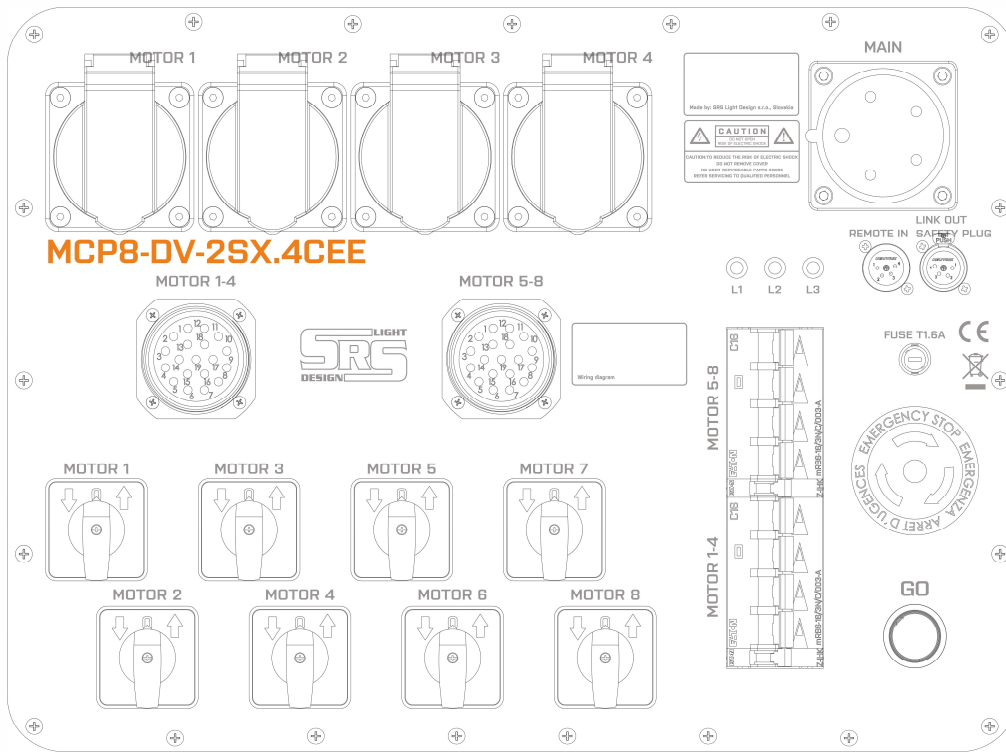

MCP8-DV-2H16.4CEE

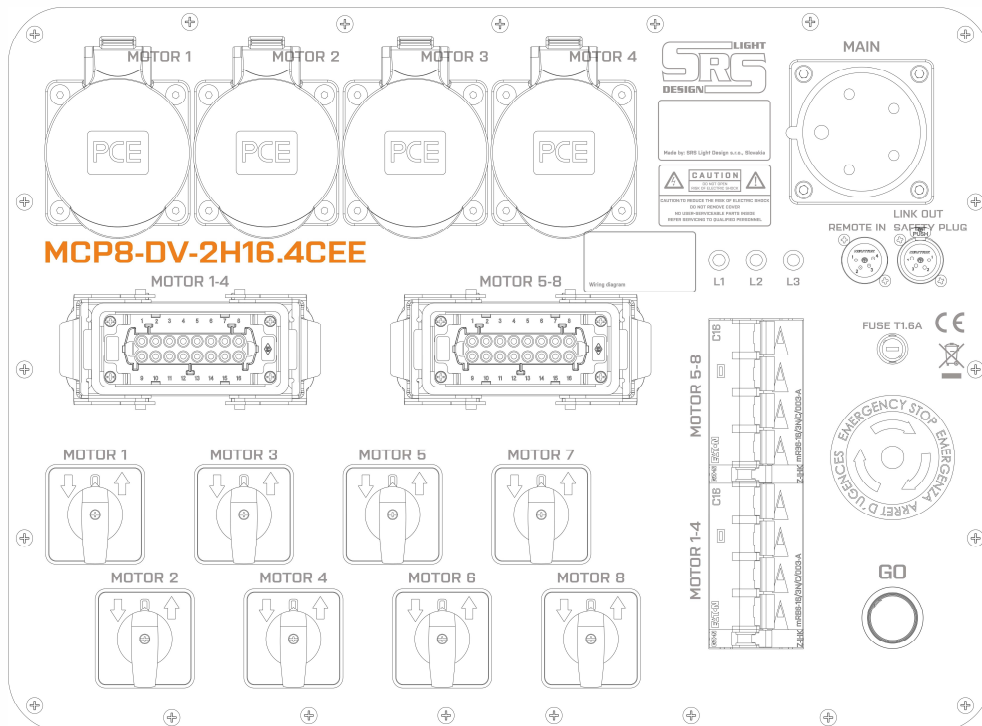

MCP8-DV-8H6

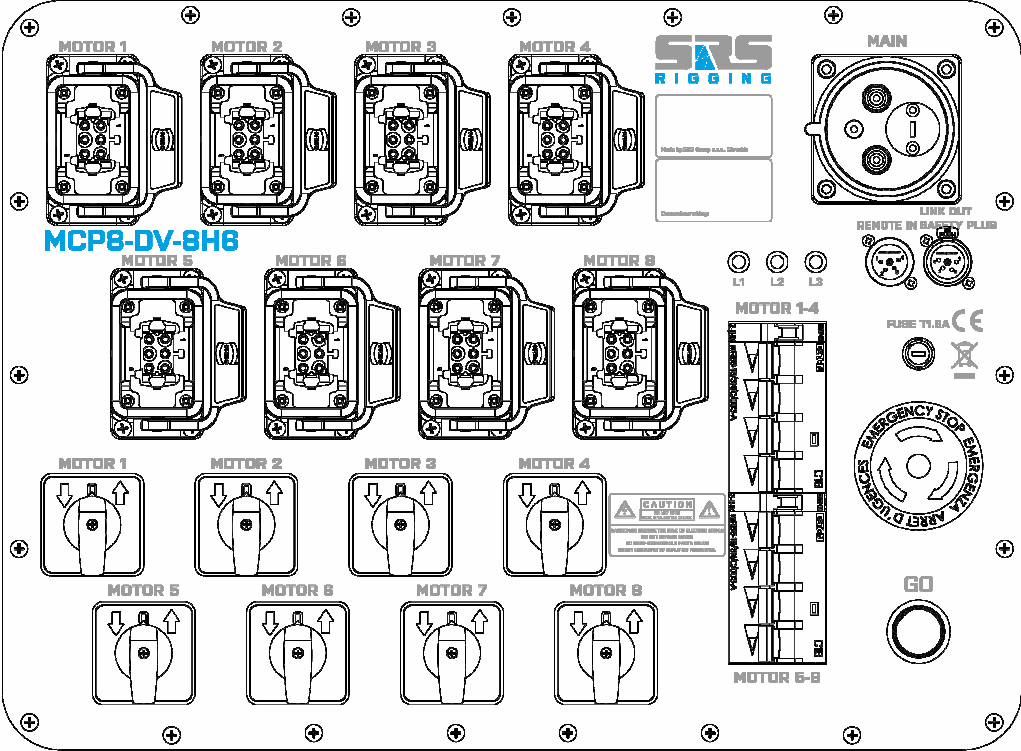

Operation

The Motors/Hoists connected to the MCP8-DV controller can be activated individually or simultaneously using the GO button located on the front panel, via cable remote or by linked controller. The selection of the hoists that are controlled is made by switches located on front panel.

Several MCP8-DV controllers can be linked together to create bigger systems.

How to start

- Connect the CEE32A/5p plug to the AC400V power supply and check control combine RCD+MCBs.
- If the main is OK the three lights display the presence of all three phases L1, L2, L3
- Connect the plugs of the electric hoists to the sockets of the CEE16A/4p or CEE16A/5p /*on request/
- Check if all emergency STOP buttons /on device and all other linked devices in system/ are released and there is presence of security plug/breach with short circuit in between pins 3 and 4 on last unit in system.

To Move a Single/Several Motor(s):

- Set the UP/DOWN switch for each motor to the desired direction.
- Hold the GO button until all motors are moved the desired height and release.

Controller normal operation:

In this mode, the controller is operated by GO and E-STOP buttons located on the front panel.

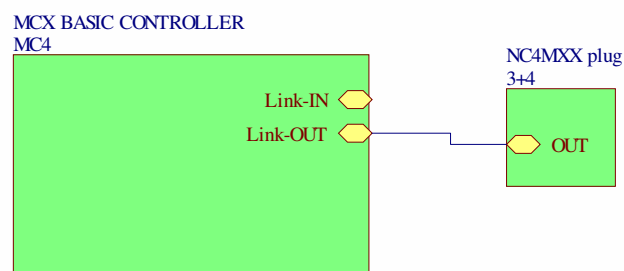

During operation, the NC4MXX plug must be connected to the last controller in chain

Controller with remote operation:

In this mode, the controller is operated by GO and E-STOP buttons located either on the front panel or on the MCP8-DV-CEE REMOTE.

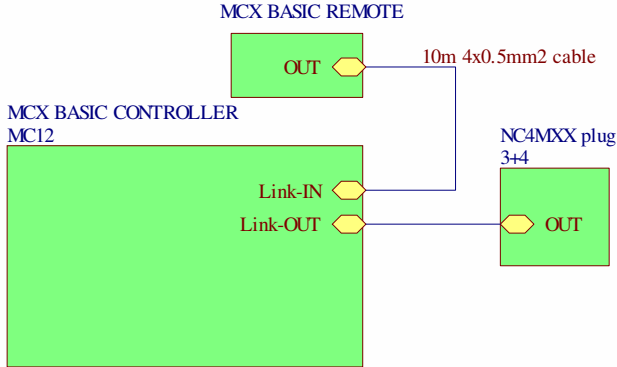

During operation, the NC4MXX plug must be connected to the last controller in chain

Controller link operation:

In this mode, all linked controllers are operated by any GO and E-STOP button located either on the front panel or on the MCP8-DV-CEEREMOTE.

Don't forget to plug the NC4MXX plug to the last controller in chain.

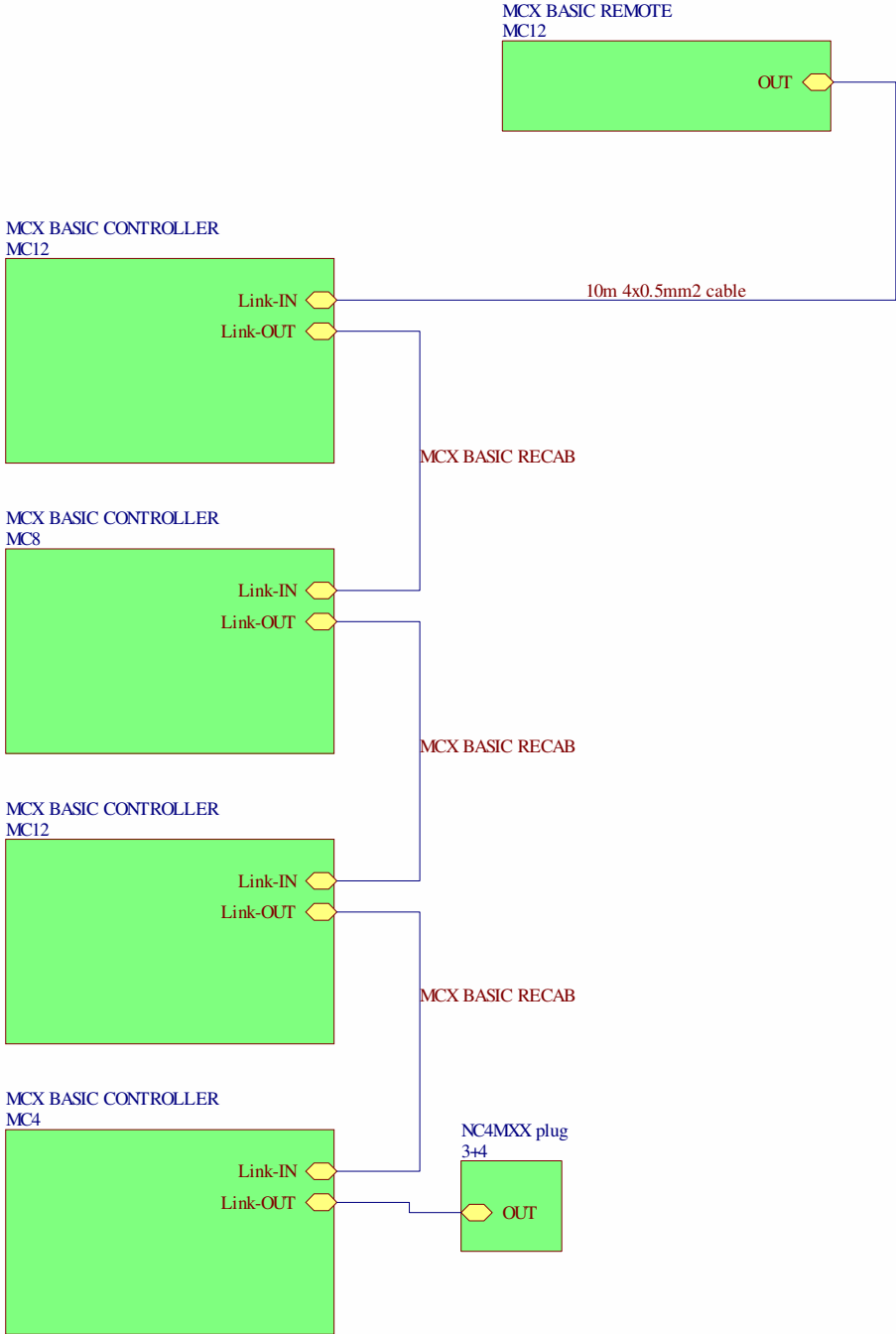

During operation, the NC4MXX plug must be connected to the last controller in chain

MCBCX.MCP REMOTE

Remote controller allows controlling of GO and E-STOP buttons for single controller or all linked controllers. Standard length of cable is 10m. The length can be altered according to customer's needs. There is also a 1m RECAP cable for linking of controllers.



STOP:

This switch protects the base unit from undesired operation and turns the MCP8-DV-CEE controller to inactive state. Stop button is of red color. Once the STOP button has been pressed, it is locked in an inactive position and must be rotated clockwise to be released.

GO:

When active, the pushbutton turns the selected channels of Hoist Control system ON. Once the GO button is released, the energizing of the hoists is turned off.

Description of connectors

LINK in/out connector

Lines 3 and 4 are normally closed – NC, by default for normal operation. Due to this, it is necessary to fit the safety breach /MXX connector/ to the link OUT connector with the short circuit between pins 3 and 4 for normal operation.

This breach must be connected to the last controller in system if the controllers are linked.

Neutrik NC4FXX

- Pin 1. Remote go in
- Pin 2. Remote go out
- Pin 3. Safety in
- Pin 4. Safety out

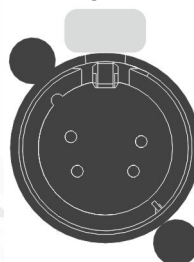

CEE16/4p motor/hoist connector

To change the direction of movement, the rotation from 123 to 132 is required. In an inactive state, this connector is without power.

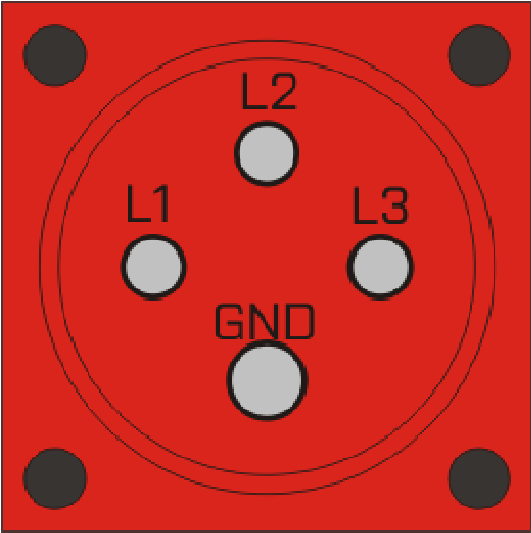

On request, unit can be equipped with CEE16/5p connector. In this case the NEUTRAL on output connector is not connected.

Harting 16-pin A-type /more common/

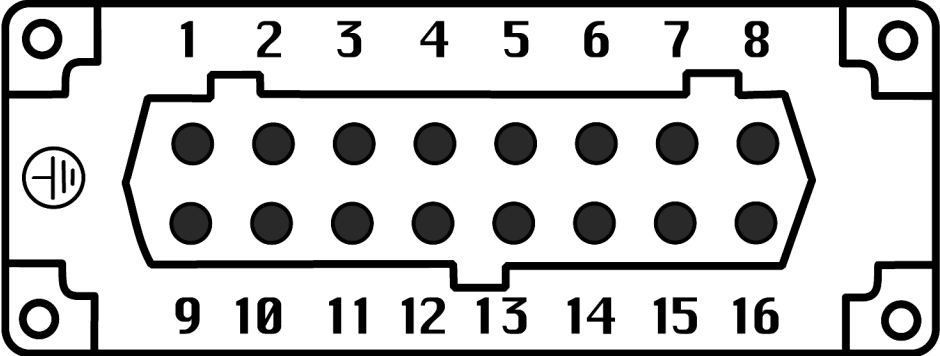

Motor 1-4	
Pin	Wire
1	L1 Motor 1
2	L2 Motor 1
3	L3 Motor 1
4	L1 Motor 2
5	L2 Motor 2
6	L3 Motor 2
7	L1 Motor 3
8	L2 Motor 3
9	L3 Motor 3
10	L1 Motor 4
11	L2 Motor 4
12	L3 Motor 4
13	GND
14	GND
15	GND
16	GND
GND	GND

Motor 5-8	
Pin	Wire
1	L1 Motor 5
2	L2 Motor 5
3	L3 Motor 5
4	L1 Motor 6
5	L2 Motor 6
6	L3 Motor 6
7	L1 Motor 7
8	L2 Motor 7
9	L3 Motor 7
10	L1 Motor 8
11	L2 Motor 8
12	L3 Motor 8
13	GND
14	GND
15	GND
16	GND
GND	GND

Motor 9-12	
Pin	Wire
1	L1 Motor 9
2	L2 Motor 9
3	L3 Motor 9
4	L1 Motor 10
5	L2 Motor 10
6	L3 Motor 10
7	L1 Motor 11
8	L2 Motor 11
9	L3 Motor 11
10	L1 Motor 12
11	L2 Motor 12
12	L3 Motor 12
13	GND
14	GND
15	GND
16	GND
GND	GND

All Housings are connected to GND/EARTH

Harting 16-pin B-type /on request/

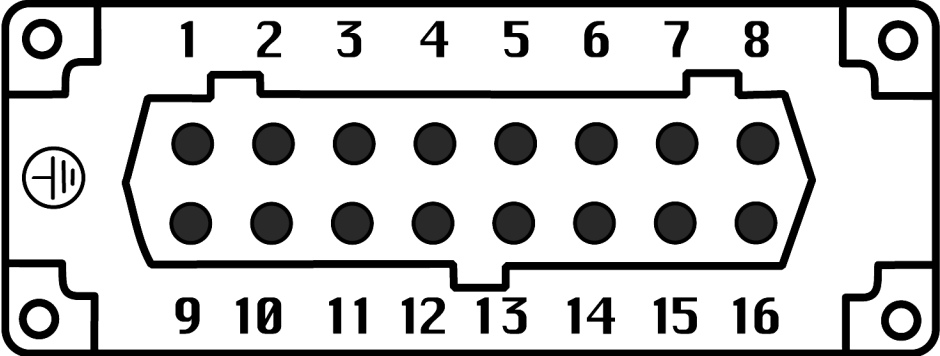

Motor 1-4	
Pin	Wire
1	L1 Motor 1
2	L2 Motor 1
3	L3 Motor 1
4	GND
5	L1 Motor 2
6	L2 Motor 2
7	L3 Motor 2
8	GND
9	L1 Motor 3
10	L2 Motor 3
11	L3 Motor 3
12	GND
13	L1 Motor 4
14	L2 Motor 4
15	L3 Motor 4
16	GND
GND	BODY+EARS

Motor 5-8	
Pin	Wire
1	L1 Motor 5
2	L2 Motor 5
3	L3 Motor 5
4	GND
5	L1 Motor 6
6	L2 Motor 6
7	L3 Motor 6
8	GND
9	L1 Motor 7
10	L2 Motor 7
11	L3 Motor 7
12	GND
13	L1 Motor 8
14	L2 Motor 8
15	L3 Motor 8
16	GND

Motor 9-12	
Pin	Wire
1	L1 Motor 9
2	L2 Motor 9
3	L3 Motor 9
4	GND
5	L1 Motor 10
6	L2 Motor 10
7	L3 Motor 10
8	GND
9	L1 Motor 11
10	L2 Motor 11
11	L3 Motor 11
12	GND
13	L1 Motor 12
14	L2 Motor 12
15	L3 Motor 12
16	GND

All Housings are connected to GND/EARTH

Harting 16-pin C-type Scan-Rig /on request/

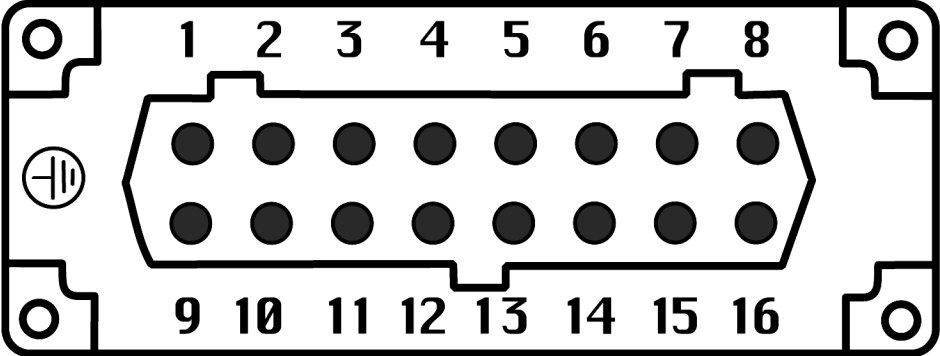

Motor 1-4	
Pin	Wire
1	L1 Motor 1
2	L2 Motor 1
3	L3 Motor 1
4	L1 Motor 2
5	L2 Motor 2
6	L3 Motor 2
7	NC
8	NC
9	L1 Motor 3
10	L2 Motor 3
11	L3 Motor 3
12	L1 Motor 4
13	L2 Motor 4
14	L3 Motor 4
15	NC
16	NC
GND	BODY+EARS

Motor 5-8	
Pin	Wire
1	L1 Motor 5
2	L2 Motor 5
3	L3 Motor 5
4	L1 Motor 6
5	L2 Motor 6
6	L3 Motor 6
7	NC
8	NC
9	L1 Motor 7
10	L2 Motor 7
11	L3 Motor 7
12	L1 Motor 8
13	L2 Motor 8
14	L3 Motor 8
15	NC
16	NC

Motor 9-12	
Pin	Wire
1	L1 Motor 9
2	L2 Motor 9
3	L3 Motor 9
4	L1 Motor 10
5	L2 Motor 10
6	L3 Motor 10
7	NC
8	NC
9	L1 Motor 11
10	L2 Motor 11
11	L3 Motor 11
12	L1 Motor 12
13	L2 Motor 12
14	L3 Motor 12
15	NC
16	NC

All Housings are connected to GND/EARTH

944056: Harting 16-pin F-type /on request/

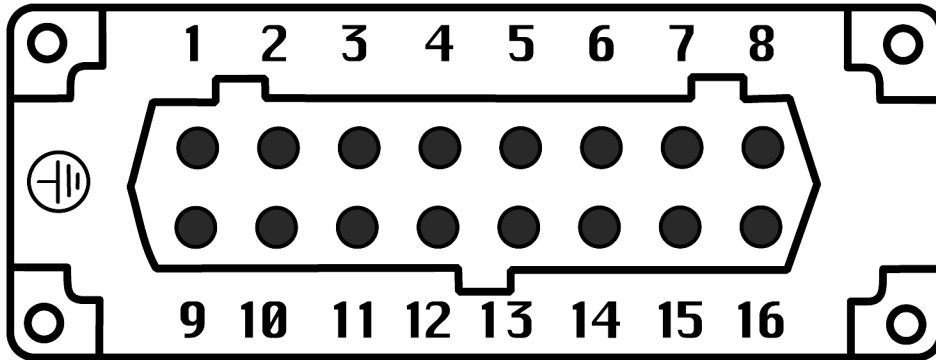

Motor 1-4	
Pin	Wire
1	L1 Motor 1
2	L2 Motor 1
3	L3 Motor 1
4	L1 Motor 2
5	L2 Motor 2
6	L3 Motor 2
7	L1 Motor 3
8	L2 Motor 3
9	L3 Motor 3
10	L1 Motor 4
11	L2 Motor 4
12	L3 Motor 4
13	NC
14	NC
15	NC
16	NC
GND	BODY+EARS

Motor 5-8	
Pin	Wire
1	L1 Motor 5
2	L2 Motor 5
3	L3 Motor 5
4	L1 Motor 6
5	L2 Motor 6
6	L3 Motor 6
7	L1 Motor 7
8	L2 Motor 7
9	L3 Motor 7
10	L1 Motor 8
11	L2 Motor 8
12	L3 Motor 8
13	NC
14	NC
15	NC
16	NC
GND	BODY+EARS

Motor 9-12	
Pin	Wire
1	L1 Motor 9
2	L2 Motor 9
3	L3 Motor 9
4	L1 Motor 10
5	L2 Motor 10
6	L3 Motor 10
7	L1 Motor 11
8	L2 Motor 11
9	L3 Motor 11
10	L1 Motor 12
11	L2 Motor 12
12	L3 Motor 12
13	NC
14	NC
15	NC
16	NC
GND	BODY+EARS

All Housings are connected to GND/EARTH

HARTING 6 female

Pin	Function	Note
1	L1	
2	L2	
3	L3	
4	NC	
5	NC	
6	NC	
BODY	PE/GROUND	

Protection and Safety:

- 2x combined MCB C16A+GFI/RCD 30mA outputs protected
- MPA – Manual Phase Align
- Mains contactor

Dimensions /W x D x H/ & Weight

MCP8-DV Plastic case: 503 x 406 x 193 mm, weight: 12kg

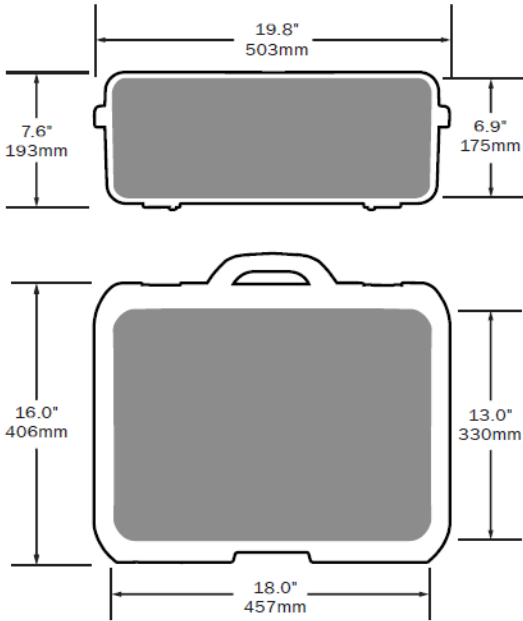

Warranty

MCP8-DV hoist controller is covered by a 2-year manufacturer's warranty. For extended warranty conditions, please contact the manufacturer at sales@srs-group.com.

The guarantee covers the original factory installed components of the controller and their correct functioning.

The warranty voids if any part or replacement component is installed or modified without authorization from the manufacturer and/or the internal circuit is tampered or modified and/or the controller is operated outside of normal using conditions – electrical power supply is not conform or there is connection error or mechanical damage of controller, including overload and improper use.

The manufacturer always helps with the repair of each unit.

Declaration of conformity

DECLARATION OF CONFORMITY

According to guidelines 89/336 EEC and 92/31 EEC, 90/337 CEE Annex II A:

Name of producer: SRS Group s.r.o.

Address of producer: Rybnicna 38/B, SK- 83106 Bratislava, Slovak Republic
www.srs-group.com / sales@srs-group.com, +421232661800

Declares that the product

Name of product: **MCP8-DV** hoist controller + variants

Types:

MCP8-DV-CEE, MCP8-DV-2SX19.4CEE, MCP8-DV-2H16.4CEE, MCP8-DV-8H6

Corresponds with following harmonized standards:

Safety: EN 60065
EN 60950
EN 60204-1
EN 13850
EN 12100-2
IEC 60364

EMC: EN55103-1, resp. EN55103-2

And

Is in compliance with following requirements:

Machinery directive: 2006/42/EC

Low Voltage directive: 2006/95/EC

Bratislava, 20 November 2015

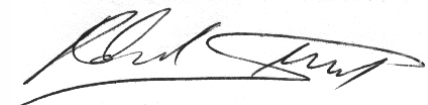

Robert Sloboda

Copyright 2017 SRS Group, s.r.o. | Specifications subject to change without notice.
Document: MCP8-DV_en_manual_M255 | Version 2.1 | Actual as of: 3 February 2020



SRS Group s.r.o.

Rybnicna 38/B | 831 07 Bratislava | Slovakia

Phone: +421 2 32 661 800

Email: sales@srs-group.com | www.srs-group.com

